

PŘÍČNÉ ŘEZY M 1:100

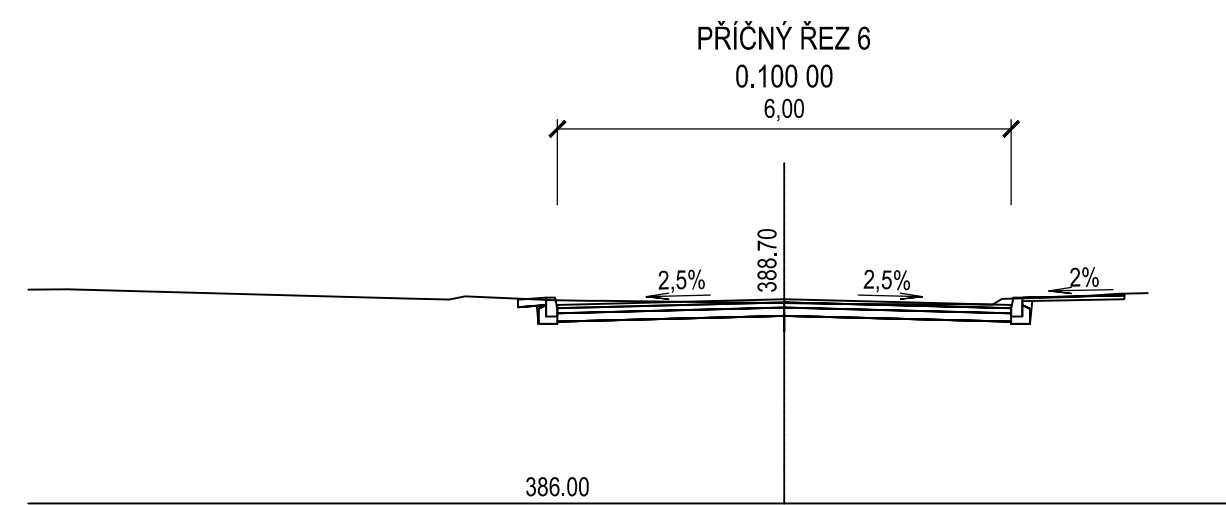
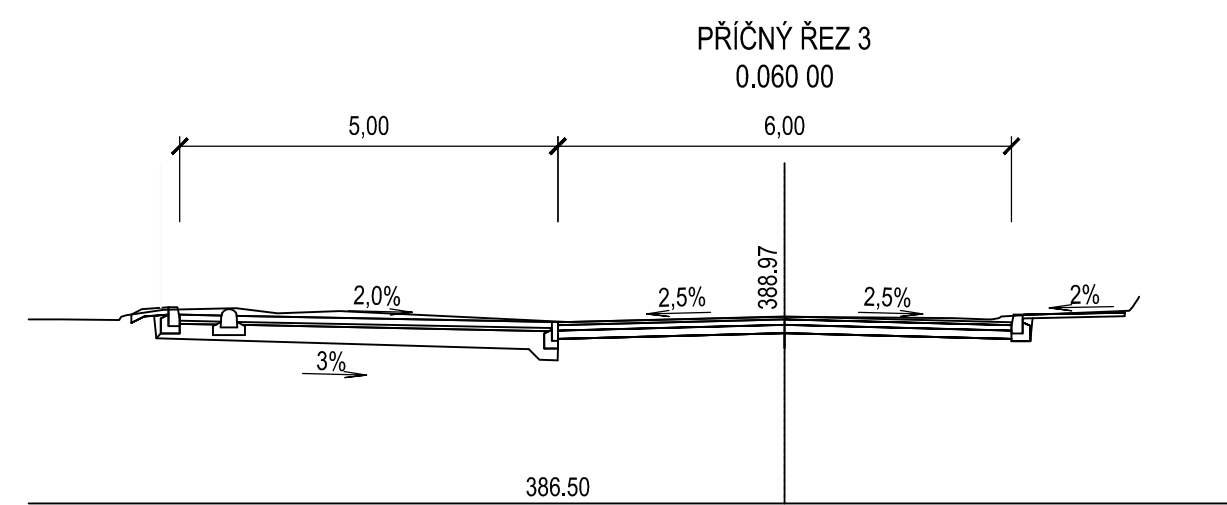
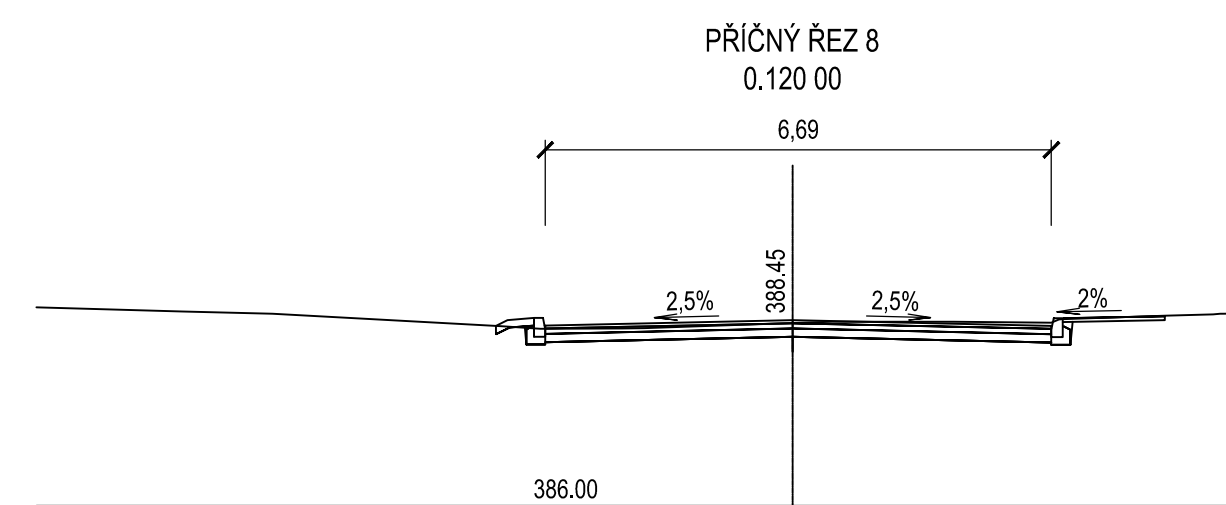
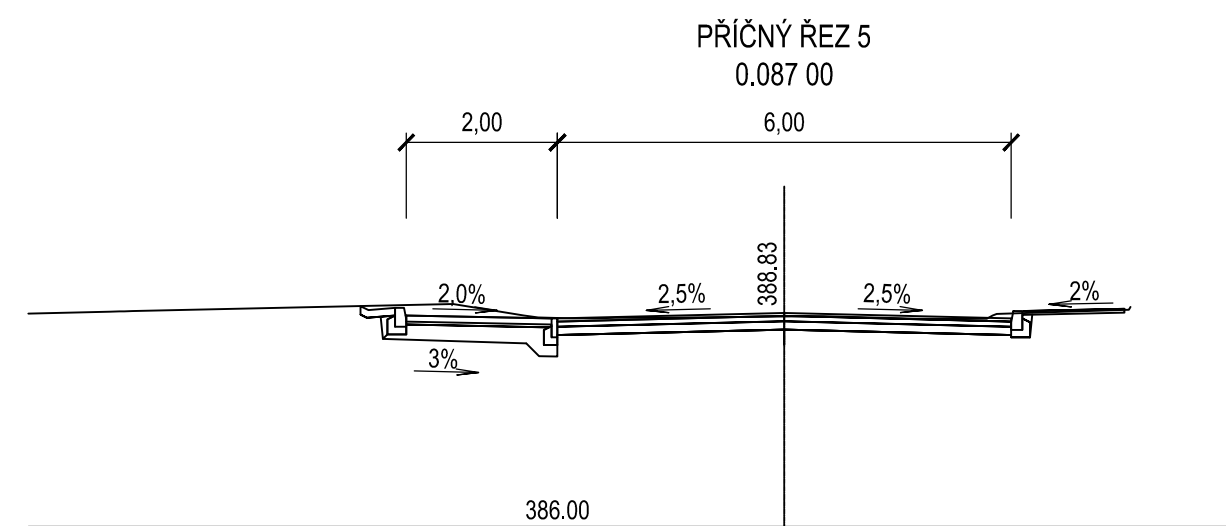
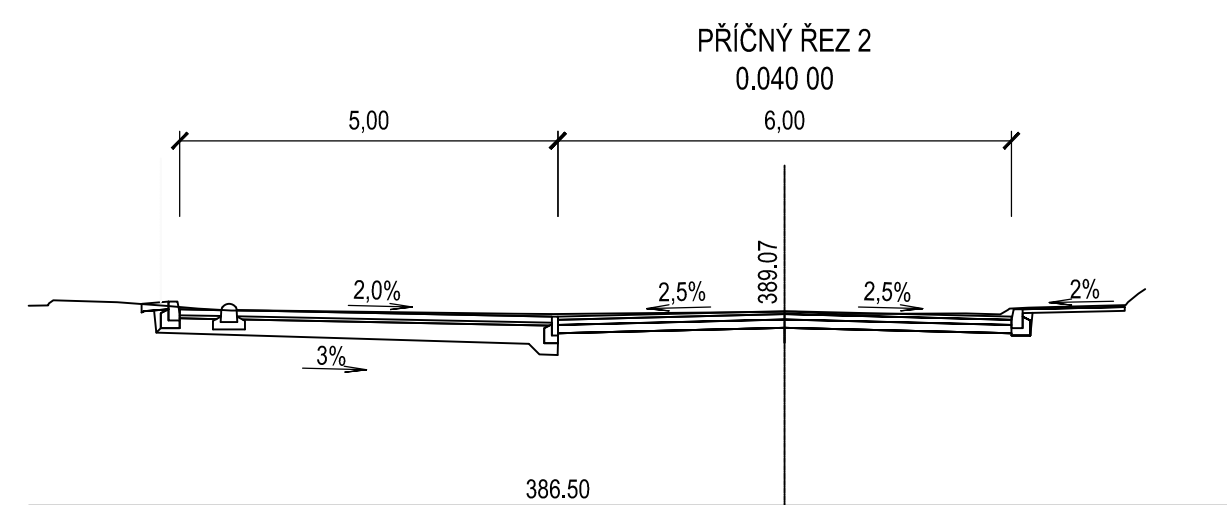
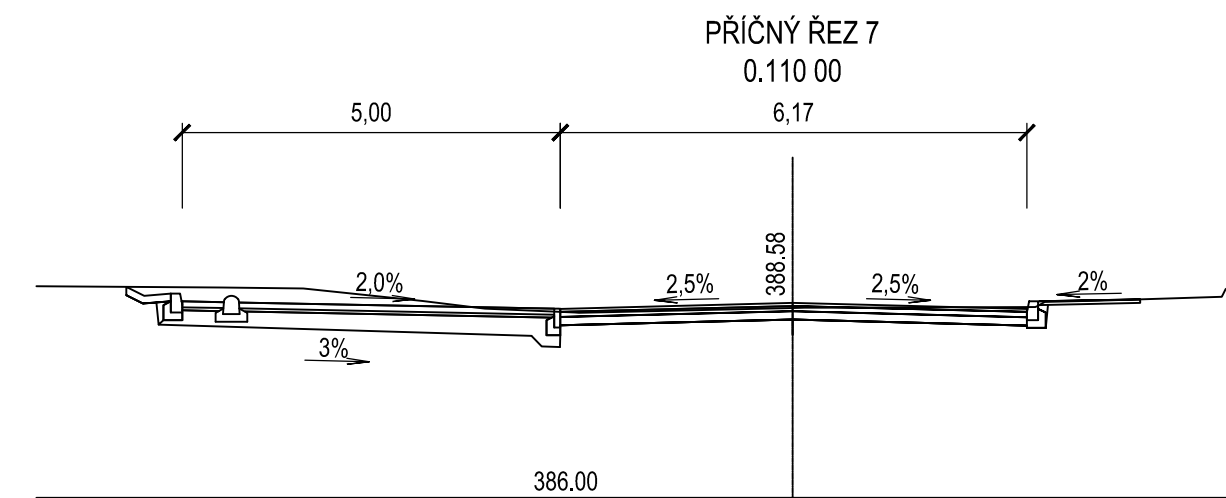
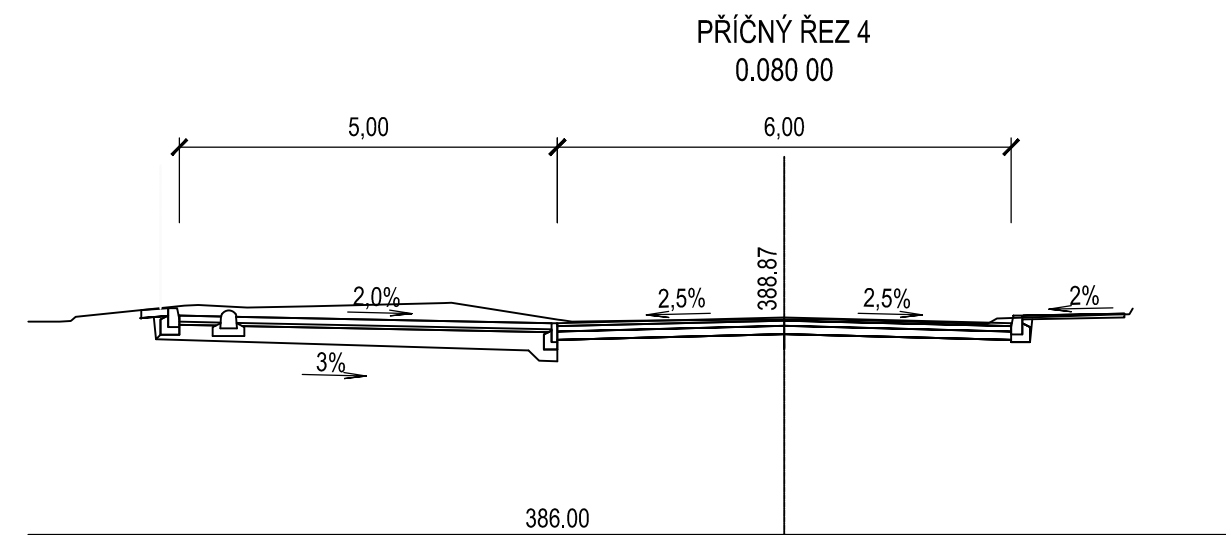
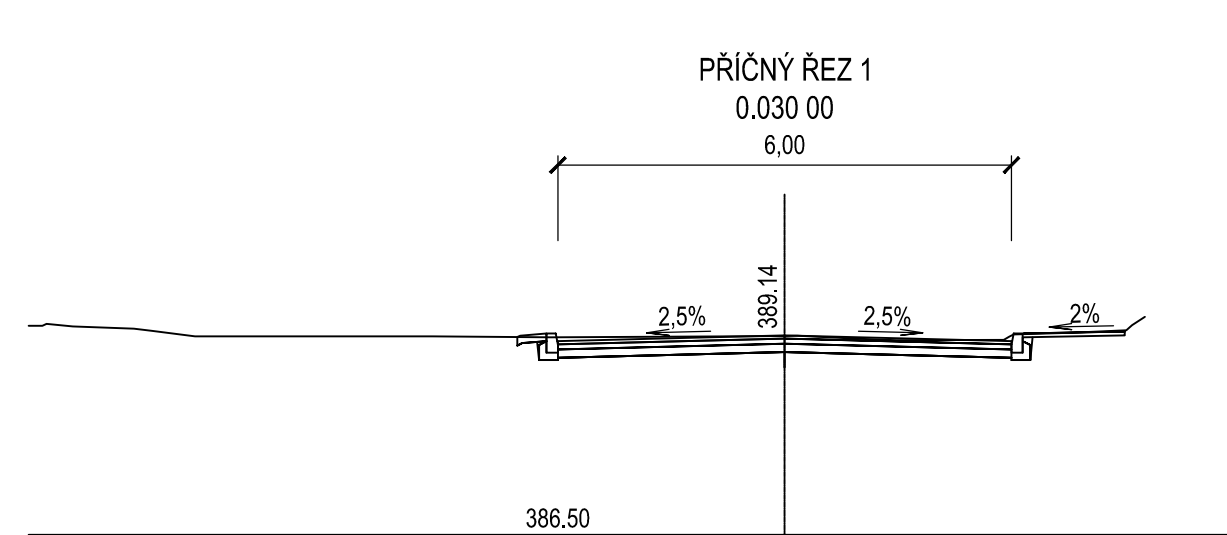

Souřadný systém S - JTSK
Výškový systém Balt p.v.

Akce
Karlovy Vary, ulice Rolavská - parkování

Objednatel STATUTÁRNÍ MĚSTO KARLOVY VARY MOSKEVSKÁ 2035/21, KARLOVY VARY, 361 20	Zhotovitel ING. TOMÁŠ ŠTEMBERA PETRÁŇ Vltavínová 1305/7, 326 00 Plzeň IČO: 108 250 61 tel.: 724 547 385 e-mail: stembera.petran@email.cz
--	---

HIP	Ing. T. Štembera Petrář	Zak. číslo	22D5007
Vypracoval	Ing. T. Štembera Petrář	Datum	02/2023
Zodp. projektant	Ing. T. Štembera Petrář	Stupeň	PDPS
Část dokumentace SO 101 KOMUNIKACE		Formát	297 x 630
		Měřítko	1:50
Příloha PŘÍČNÉ ŘEZY		Č. přílohy	Paré
		2.d	